



**NSC31 - 31,000 Grain Water Softener**

**APPLICATIONS**

- Medium to large households

**FEATURES**

- AutoSense technology
- Low salt monitor
- High capacity media
- Installation kit
- High flow valve for optimal water pressure
- 8 ppm clear water (ferrous) iron removal
- Built-in tank light

**DIMENSIONS**

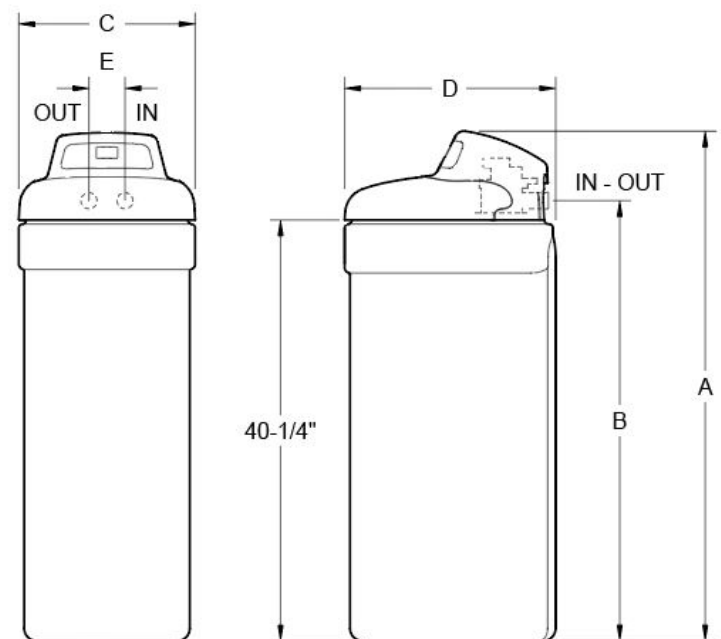

A	B	C	D	E
47.75"	41.5"	16.5"	19.75"	3.375"

**SPECIFICATIONS**

- Model number: GW-NSC31
- Household size: 1-5+
- Max capacity: 31,300
- Resin (cu. ft.): 0.81
- Standard connection size: 1" NPT
- Valve: 3/4"
- Rated service flow rate (gpm): 7.2
- Intermittent flow rate (gpm @ 30 psi drop): 11.8
- Clear water iron removal (ppm): 8
- Electronic demand: Yes
- Maximum efficiency (grains removed per lb of salt): 5,090



## NSC42 - 42,000 Grain Water Softener

### APPLICATIONS

- Any sized households

### FEATURES

- AutoSense technology
- Low salt monitor
- High capacity media
- Installation kit
- Ultra high flow valve for up to 1" plumbing delivers maximum water pressure
- 11ppm clear water (ferrous) iron removal
- Premium electronic board displays average daily gallons, flow rate, salt level and more
- Self-cleaning sediment filter, with no filters to replace
- Built-in tank light

### DIMENSIONS

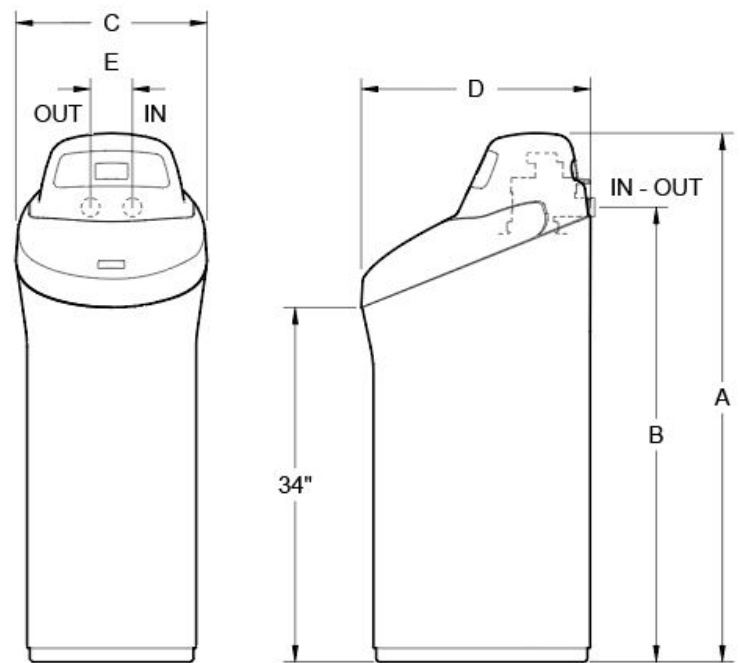

### SPECIFICATIONS

- Model number: GW-NSC42
- Household size: All
- Max capacity: 42,100
- Resin (cu. ft.): 1.20
- Standard connection size: 1" NPT
- Valve: 1"
- Rated service flow rate (gpm): 9.9
- Intermittent flow rate (gpm @ 30 psi drop): 17.8
- Clear water iron removal (ppm): 11
- Electronic demand: Yes
- Maximum efficiency (grains removed per lb of salt): 4,940

A	B	C	D	E
48"	41.5"	17"	21"	3.75"